

●H型：2/3圓周有孔管

吸水孔 (9孔/周)

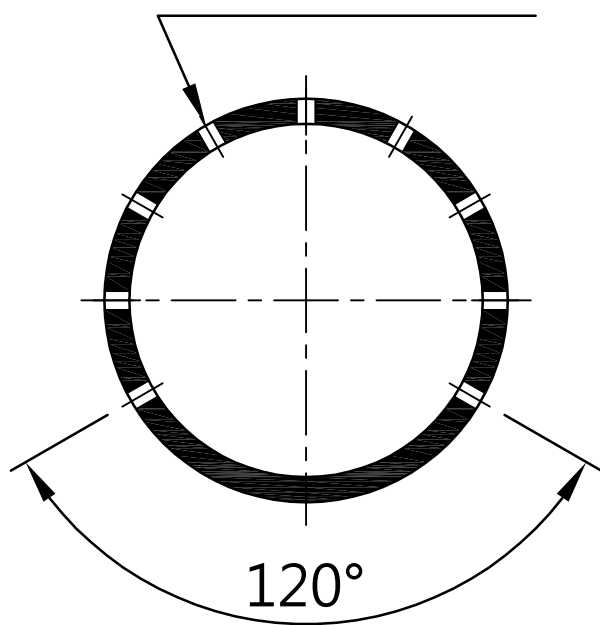

TP-H型  
螺旋浪管

